

## Product Description

Stanford Microdevices' SGA-4563 is a high performance cascadeable 50-ohm amplifier designed for operation at voltages as low as 3.4V. This RFIC uses the latest Silicon Germanium Heterostructure Bipolar Transistor (SiGe HBT) process featuring 1 micron emitters with  $F_T$  up to 50 GHz.

This circuit uses a Darlington pair topology with resistive feedback for broadband performance as well as stability over its entire temperature range. Internally matched to 50 Ohm impedance, the SGA-4563 requires only DC blocking and bypass capacitors for external components.

Small Signal Gain vs. Frequency

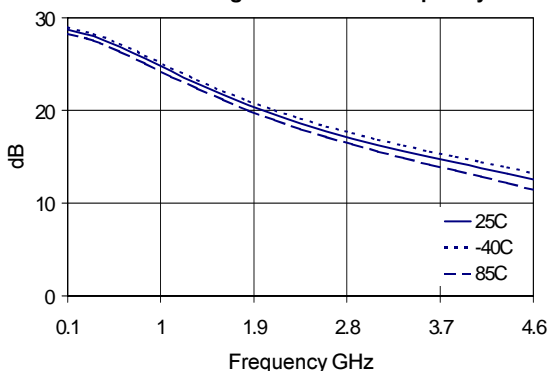

## SGA-4563

### DC-2500 MHz, Silicon Germanium Cascadeable Gain Block



### Product Features

- DC-2500 MHz Operation
- Single Voltage Supply
- Low Current Draw: 45mA at 3.5V typ.
- High Output Intercept: 26 dBm typ. at 1950MHz

### Applications

- Oscillator Amplifiers
- Broadband Gain Blocks
- IF/RF Buffer Amplifiers

Symbol	Parameters: Test Conditions: $Z_0 = 50 \text{ Ohms}$ , $I_D = 45 \text{ mA}$ , $T = 25^\circ\text{C}$	Units	Min.	Typ.	Max.
$P_{1dB}$	Output Power at 1dB Compression	f = 850 MHz f = 1950 MHz f = 2400 MHz	dBm dBm dBm	15.0 12.8 11.6	
$IP_3$	Third Order Intercept Point Power out per tone = -10 dBm	f = 850 MHz f = 1950 MHz f = 2400 MHz	dBm dBm dBm	27.1 26.2 25.3	
$S_{21}$	Small Signal Gain	f = 850 MHz f = 1950 MHz f = 2400 MHz	dB dB dB	25.5 20.0 18.5	
Bandwidth	Input and Output VSWR: Minimum 2:1		MHz	2500	
$S_{11}$	Input VSWR	f = 1950 MHz	-	1.2:1	
$S_{22}$	Output VSWR	f = 1950 MHz	-	1.9:1	
$S_{12}$	Reverse Isolation	f = 850 MHz f = 1950 MHz f = 2400 MHz	dB dB dB	28.0 24.5 23.0	
NF	Noise Figure	f = 1950 MHz	dB	2.4	
$V_D$	Device Voltage		V	3.5	
$R_{th, j-l}$	Thermal Resistance (junction - lead)		$^\circ\text{C/W}$	255	

The information provided herein is believed to be reliable at press time. Stanford Microdevices assumes no responsibility for inaccuracies or omissions. Stanford Microdevices assumes no responsibility for the use of this information, and all such information shall be entirely at the user's own risk. Prices and specifications are subject to change without notice. No patent rights or licenses to any of the circuits described herein are implied or granted to any third party. Stanford Microdevices does not authorize or warrant any Stanford Microdevices product for use in life-support devices and/or systems. Copyright 2001 Stanford Microdevices, Inc. All worldwide rights reserved.

**SGA-4563 DC-2.5 GHz 3.5V SiGe Amplifier**

**Absolute Maximum Ratings**

Operation of this device above any one of these parameters may cause permanent damage.

Bias Conditions should also satisfy the following expression:  $I_D V_D (\text{max}) < (T_J - T_{OP})/R_{\theta j-l}$

Parameter	Value	Unit
Supply Current	90	mA
Device Voltage	6	V
Operating Temperature	-40 to +85	°C
Maximum Input Power	+10	dBm
Storage Temperature Range	-40 to +150	°C
Operating Junction Temperature	+150	°C

**Key parameters, at typical operating frequencies:**

Parameter	Typical 25°C	Unit	Test Condition ( $I_D = 45\text{mA}$ , unless otherwise noted)
<b>100 MHz</b>			
Gain	28.7	dB	Tone spacing = 1 MHz, Pout per tone = -10dBm  $Z_s = 50 \text{ Ohms}$
Output IP3	27.0	dBm	
Output P1dB	15.7	dBm	
Input Return Loss	19.2	dB	
Reverse Isolation	30.5	dB	
Noise Figure	1.9	dB	
<b>500 MHz</b>			
Gain	27.4	dB	Tone spacing = 1 MHz, Pout per tone = -10dBm  $Z_s = 50 \text{ Ohms}$
Output IP3	26.2	dBm	
Output P1dB	15.0	dBm	
Input Return Loss	20.7	dB	
Reverse Isolation	29.7	dB	
Noise Figure	1.9	dB	
<b>850 MHz</b>			
Gain	25.6	dB	Tone spacing = 1 MHz, Pout per tone = -10dBm  $Z_s = 50 \text{ Ohms}$
Output IP3	27.1	dBm	
Output P1dB	15.0	dBm	
Input Return Loss	24.5	dB	
Reverse Isolation	28.7	dB	
Noise Figure	1.9	dB	
<b>1950 MHz</b>			
Gain	20.2	dB	Tone spacing = 1 MHz, Pout per tone = -10dBm  $Z_s = 50 \text{ Ohms}$
Output IP3	26.2	dBm	
Output P1dB	12.8	dBm	
Input Return Loss	19.9	dB	
Reverse Isolation	24.5	dB	
Noise Figure	2.4	dB	
<b>2400 MHz</b>			
Gain	18.6	dB	Tone spacing = 1 MHz, Pout per tone = -10dBm  $Z_s = 50 \text{ Ohms}$
Output IP3	25.3	dBm	
Output P1dB	11.6	dBm	
Input Return Loss	16.5	dB	
Reverse Isolation	23.0	dB	

**SGA-4563 DC-2.5 GHz 3.5V SiGe Amplifier**

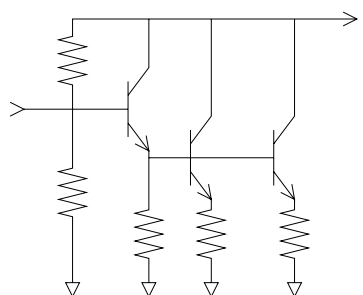
Pin #	Function	Description	Device Schematic
1	GND	Connection to ground. For best performance use via holes (as close to ground leads as possible) to reduce lead inductance.	
2	GND	Same as Pin 1	
3	RF IN	RF input pin. This pin requires the use of an external DC blocking capacitor chosen for the frequency of operation.	
4	GND	Same as Pin 1	
5	GND	Same as Pin 1	
6	RF OUT	RF output and bias pin. Bias should be supplied to this pin through an external series resistor and RF choke inductor. Because DC biasing is present on this pin, a DC blocking capacitor should be used in most applications (see application schematic). The supply side of this bias network should be well bypassed.	

**Application Schematic**

Recommended 1% Bias Resistor Values				
Supply Voltage(Vs)	5V	8.0V	9V	12V
Rbias (Ohms)	33.2	100	121	187

Note: A bias resistor is needed for stability over temperature.

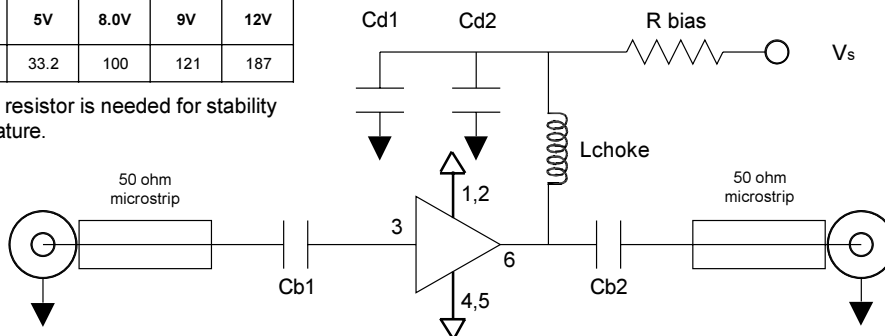

Reference Designator	Function	500 MHz	850 MHz	1950 MHz	2400 MHz
Cb1	DC Blocking	220 pF	100 pF	68 pF	56 pF
Cb2	DC Blocking	220 pF	100 pF	68 pF	56 pF
Cd1	Decoupling	1 uF	1 uF	1 uF	1 uF
Cd2	Decoupling	100 pF	68 pF	22 pF	22 pF
Lchoke	AC Blocking	68 nH	33 nH	22 nH	18 nH

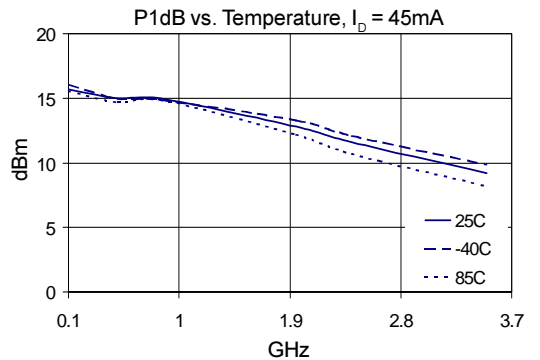
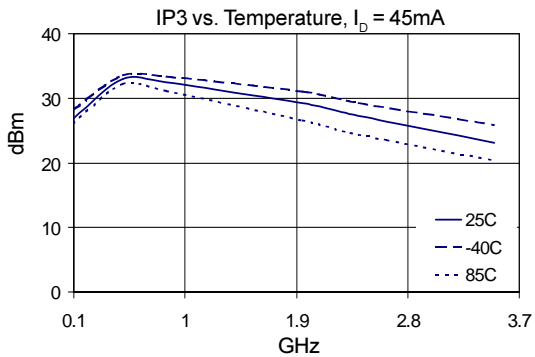
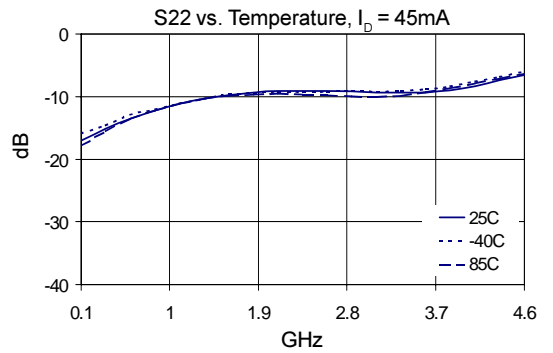
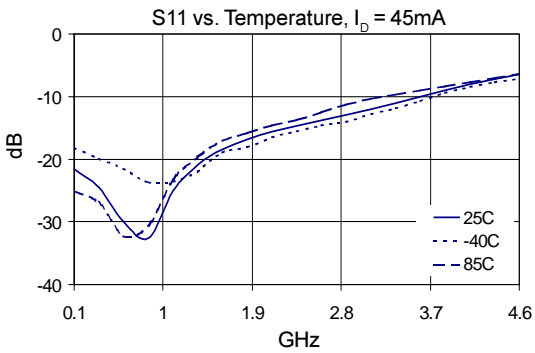
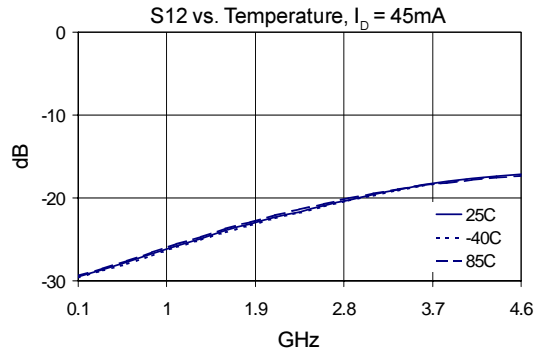
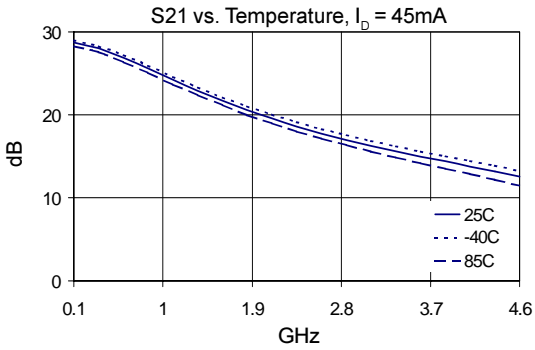
**SGA-4563 DC-2.5 GHz 3.5V SiGe Amplifier**



**Caution: ESD sensitive**  
Appropriate precautions in handling, packaging and testing devices must be observed.

**Part Number Ordering Information**

Part Number	Reel Size	Devices/Reel
SGA-4563	7"	3000

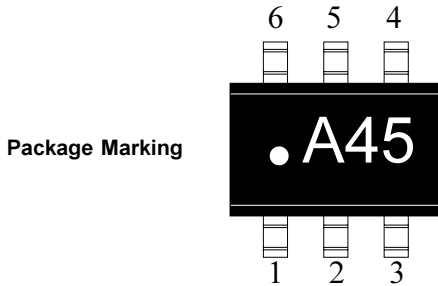

Note: Pin 1 is on lower left when you can read package marking

**Package Dimensions**

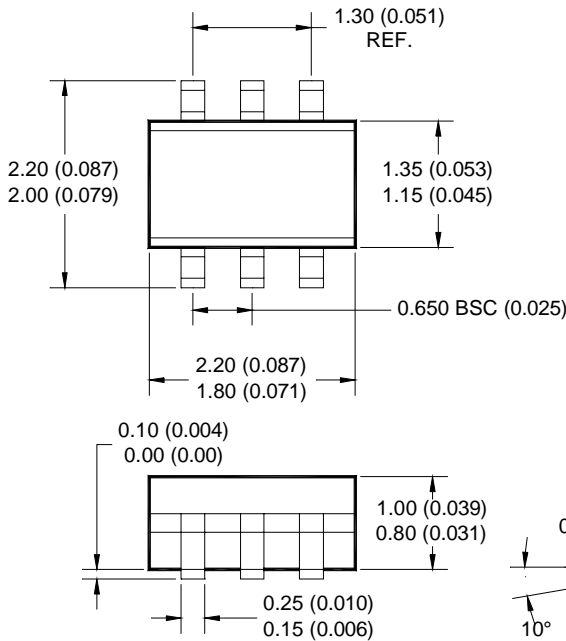

**Pad Layout**

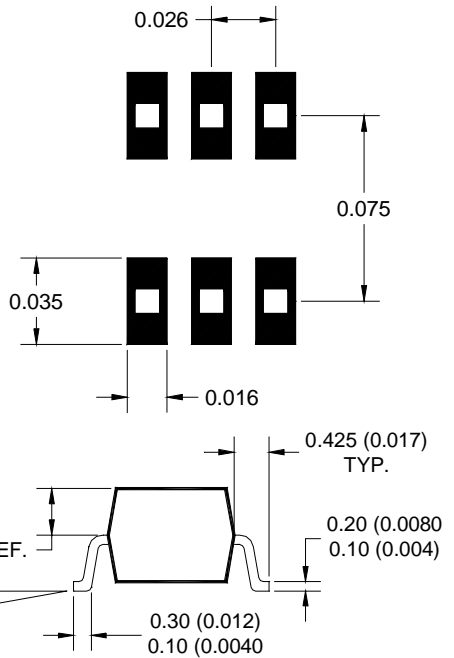

DIMENSIONS ARE IN INCHES [MM]