

Subminiature Coaxial Switch 1.6 mm High, DC to 6 GHz

MS-156 Series

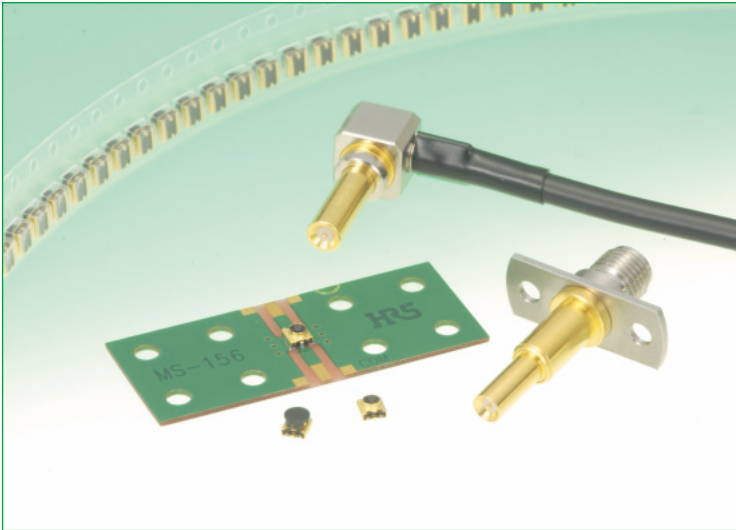

Overview

Developed for inspection of high frequency circuits used in portable terminals. Verification of the circuit performance is accomplished by simply inserting the external plug in the board mounted receptacle. This action re-directs the circuit from normal condition to the plug side. Removing the plug restores circuit to its normal condition.

Space-saving design
Low profile -1.6 mm protrusion above the board.
Lightweight -0.025 g. total weight.

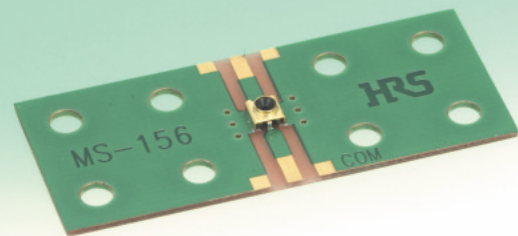

MS-156

Features

- 1. Low insertion loss**
0.1 dB typical at 6 GHz (not mated with the plug).
- 2. Space-saving design**
2.7 mm x 2.7 mm occupied board space.
- 3. Low profile**
1.6 mm protrusion above the board.
- 4. Lightweight**
0.025 g. total weight (without vacuum cap).
- 5. Durability**
100 mating/unmating cycles, with corresponding plug.
- 6. Performs over a wide frequency range**
Applicable frequencies range over a wide band, from DC to 6 GHz.
- 7. Board placement with automatic equipment**
Packaged on tape-and-reel. Also available with a vacuum cap over each switch.
- 8. Supports lead-free environments**
All components use lead-free materials.

Applications

Portable terminals, ETC, notebook computers (Bluetooth), wireless LAN, POS terminals, GPS terminals, PDA, and any small devices requiring verification of antenna/circuit performance.

Several types of plugs

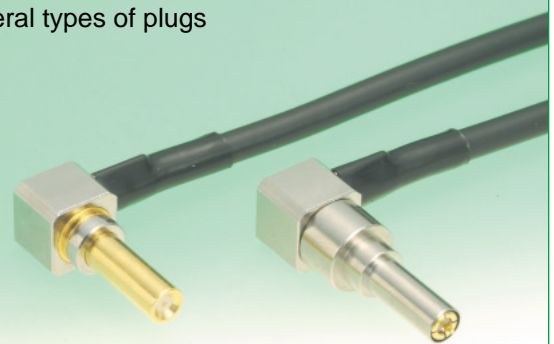

Several types of SMA conversion adapters

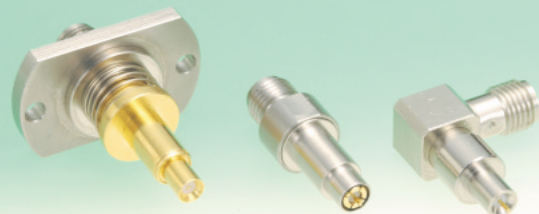

■Product Specifications

	Not mated with the plug	Mated (MS-156-HRMJ-3)
Operating temperature range	-40°C to +85°C	-40°C to +85°C
Rated power	2W	2W
Frequency range	DC to 6GHz	DC to 6GHz
Insertion loss	0.1 dB max.(DC to 3.0GHz) 0.15 dB max.(3.0GHz to 6.0GHz)	0.5 dB max.(DC to 3.0GHz) 1.2 dB max.(3.0GHz to 6.0GHz)
Isolation loss	20 dB max.(DC to 2.0GHz) 15 dB max.(2.0GHz to 4.0GHz) 13 dB max.(4.0GHz to 6.0GHz)	
V.S.W.R	1.2 max.(DC to 2.5GHz) 1.3 max.(2.5GHz to 6.0GHz)	1.4 max.(DC to 3.0GHz) 1.8 max.(3.0GHz to 6.0GHz)

Item	Specification	Conditions
1. Contact resistance	100 m ohms max.	100 mA max.
2. Insulation resistance	1000 M ohms min.	100 V DC
3. Withstanding voltage	No flashover or insulation breakdown	100 V AC / 1 minute
4. Vibration	No electrical discontinuity of 1 μ s or more	Frequency:10 to 55 Hz, single amplitude of 0.75 mm, 2 hours in each of the 3 axis.
5. Shock		Acceleration of 490 m/s ² , 6 ms duration, sine half-wave waveform, 3 cycles in each of the 3 axis
6. Thermal shock	Contact resistance: 100 m ohms max. Insulation resistance: 10 M ohms min.	Temperature: -55°C → +5°C to +35°C → +85°C → +5°C to +35°C Time: 30 → 2 to 3 → 30 → 2 to 3 (Minutes) 100 cycles
7. Durability (mating/un-mating, with corresponding plug)	Contact resistance: 100 m ohms max.	100 cycles

■Materials

Part	Material	Finish	Remarks
Shell	Phosphor bronze	Gold plating	————
Insulator	9T Nylon	————	UL94V0
Common terminal	Beryllium copper	Gold plating	————
Antenna terminal	Phosphor bronze	Gold plating	————

◆ Typical Data

● NORMALLY CLOSED(N.C)~(Not mated with the plug)

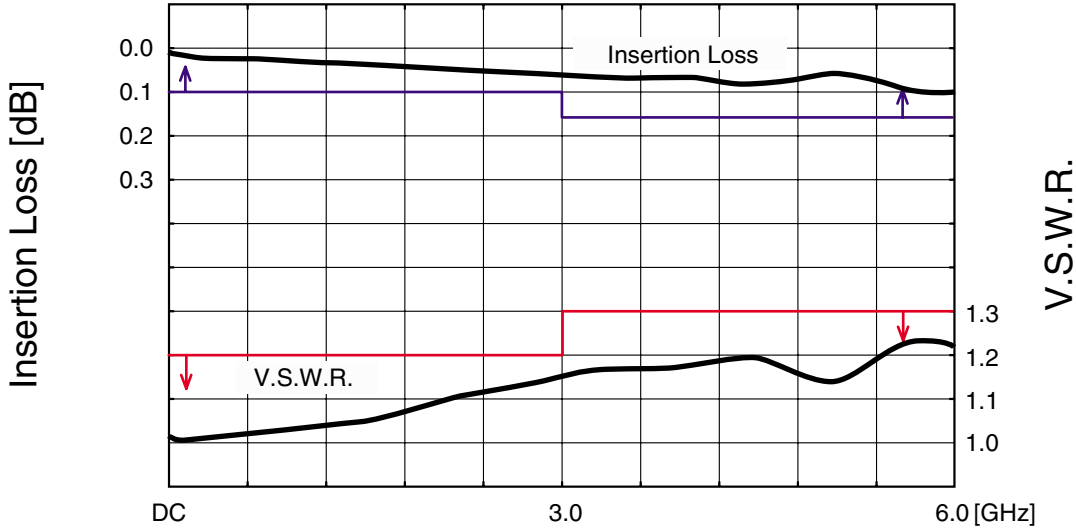

● OPEN(N.O)~(Mated with the plug)

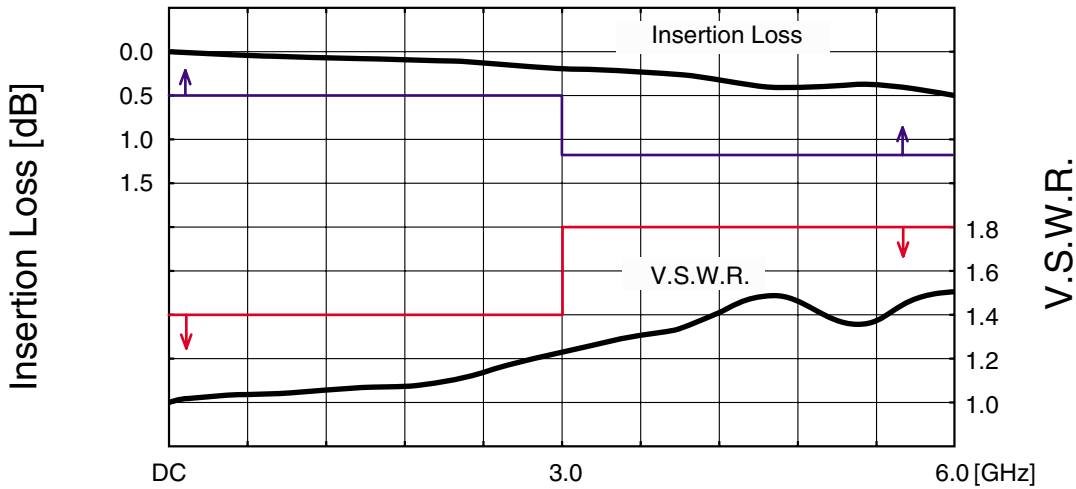

● ISOLATION

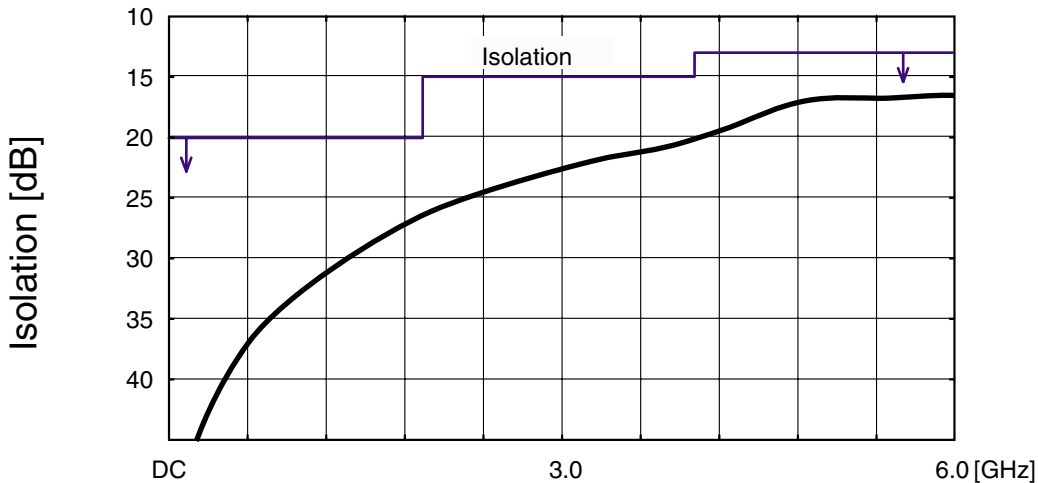

■ Receptacle

● Without vacuum cap

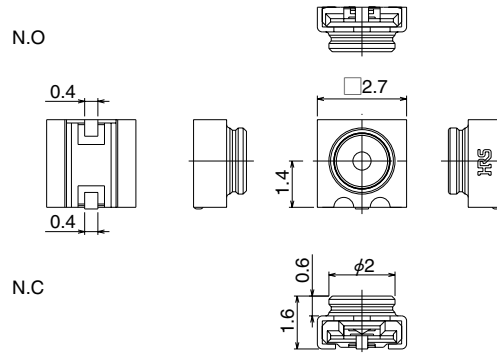

Part Number	CL No.	Packaging
MS-156	358-0167-8	2,000 pieces/reel

● With vacuum cap

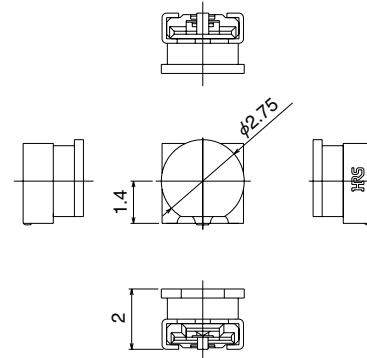
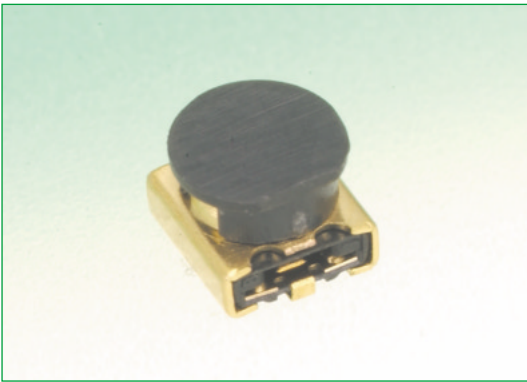

Note: Vacuum cap flat can be oriented in any direction. Orientation will not affect placement of the switch on the board.

Part Number	CL No.	Packaging
MS-156(02)	358-0167-8-02	1,500 pieces/reel

◆ Circuit diagram

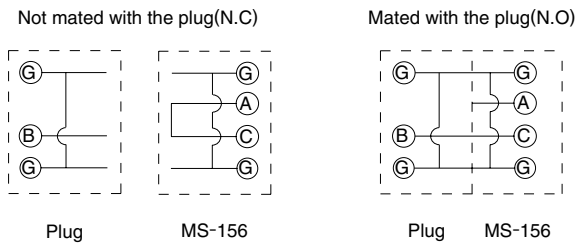

◆ PCB mounting pattern

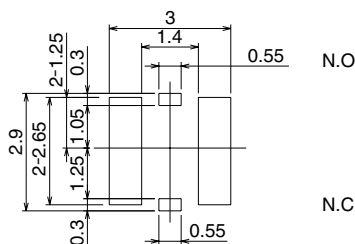

◆ Packaging Specifications

● Embossed Carrier Tape Dimensions (Without vacuum cap)

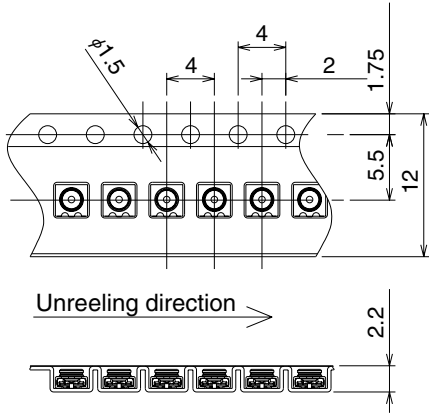

● Reel dimensions

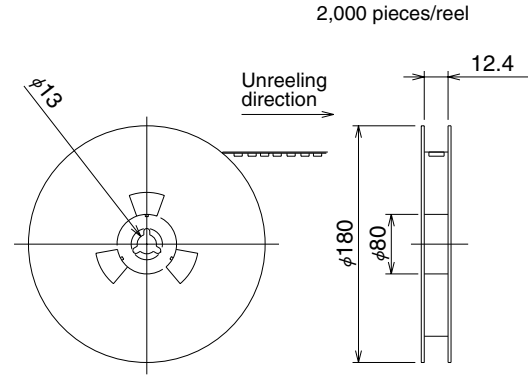

● Embossed Carrier Tape Dimensions (With vacuum cap)

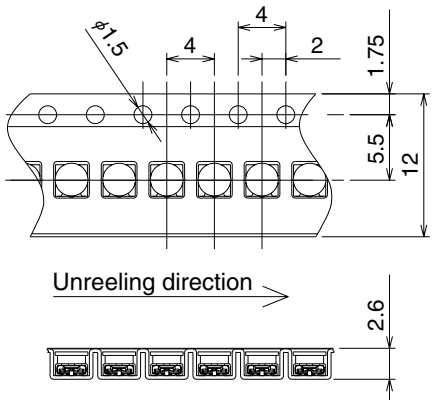

● Reel dimensions

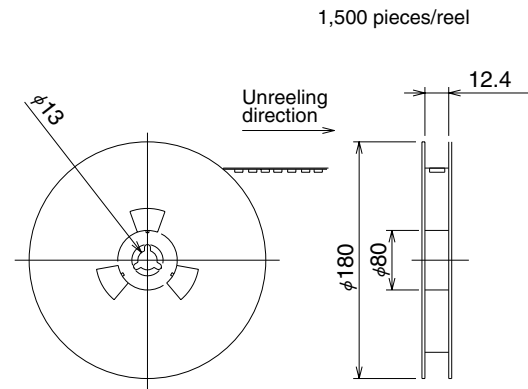

◆ Recommended Nozzle Dimensions

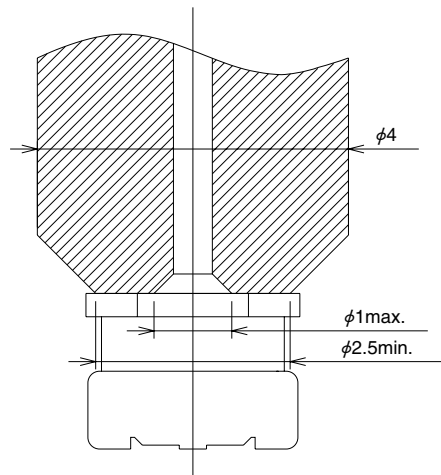

Plugs

● Press down type

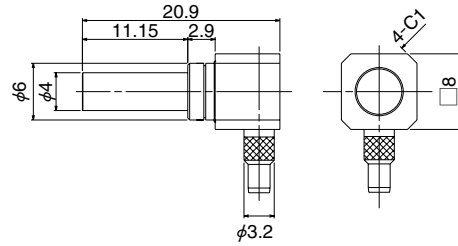

Part Number	CL No.	Durability
MS-156-C(LP)-1	358-0173-0	10,000 Times

Applicable cable: 1.5D-HQEW, 1.5D-QEW (Fujikura Ltd.)

● Simplified lock type

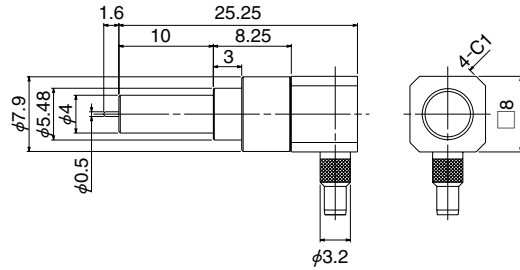

Part Number	CL No.	Durability
MS-156-C(LP)-2	358-0174-3	500 Times

Applicable cable: 1.5D-HQEW, 1.5D-QEW (Fujikura Ltd.)

SMA Conversion Adapters

● Simplified lock type, Straight

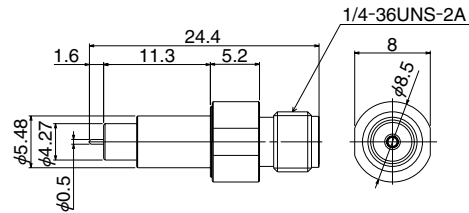

Part Number	CL No.	Durability
MS-156-HRMJ-2	358-0170-2	500 Times

● Simplified lock type, Straight

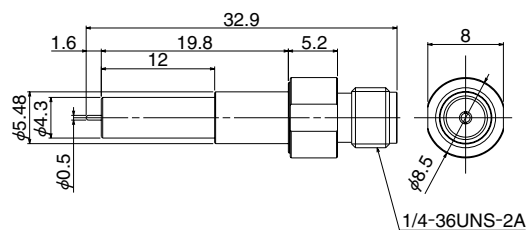

Part Number	CL No.	Durability
MS-156-HRMJ-5	358-0177-1	500 Times

●Press down type,Right angle

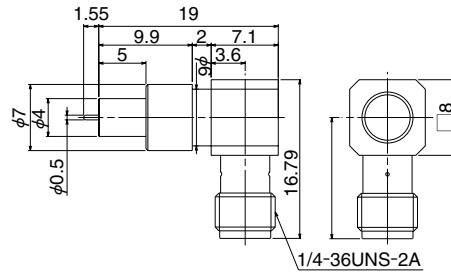

Part Number	CL No.	Durability
MS-156LP-HRMJ-1	358-0175-6	10,000 Times

●Press down type, with flange

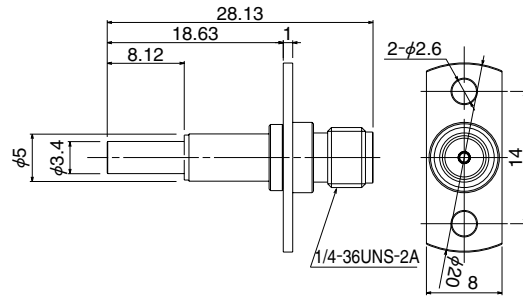

Part Number	CL No.	Durability
MS-156-HRMJ-3	358-0171-5	10,000 Times

●Press down type, with flange
(Increased self alignment)

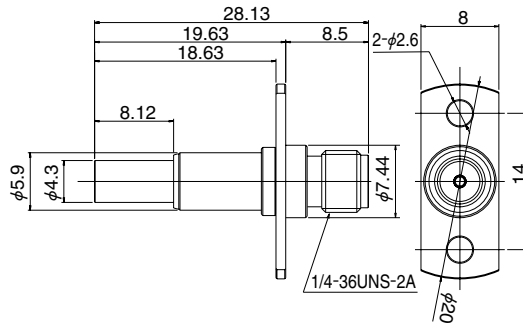

Part Number	CL No.	Durability
MS-156-HRMJ-6	358-0181-9	10,000 Times

●Floating type

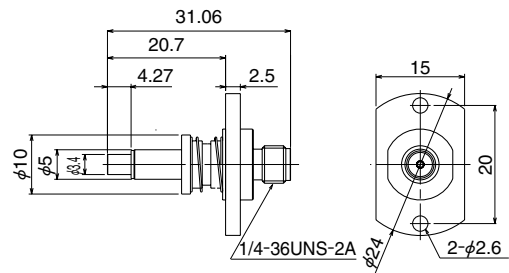

Part Number	CL No.	Durability
MS-156-HRMJ-9	358-0180-6	10,000 Times

◆ Recommended Temperature Profile

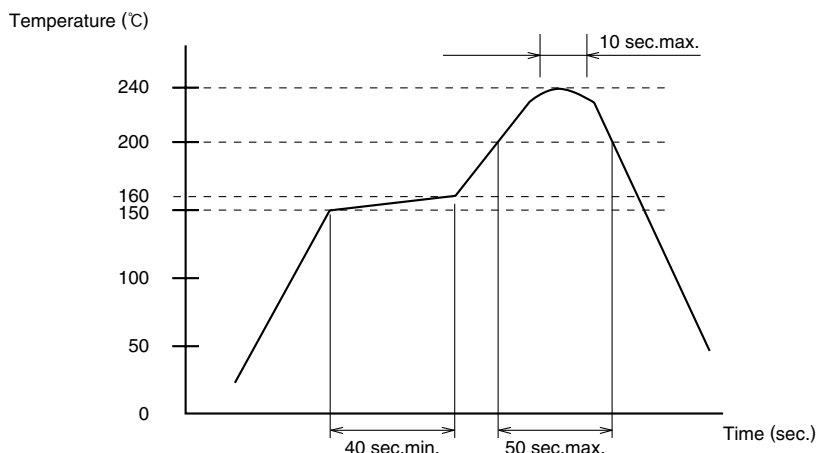

Using Typical Solder Paste

① Maximum temperature	: 240°C
② Peak temperature time	: 10 sec. max.
③ Peak temperature	: 220°C to 235°C
④ 200°C min.	: 50 sec. max.
⑤ 150°C to 160°C	: 40 sec. min.

Metal mask thickness : 0.12 mm
 Reflow cycles : 2 cycles

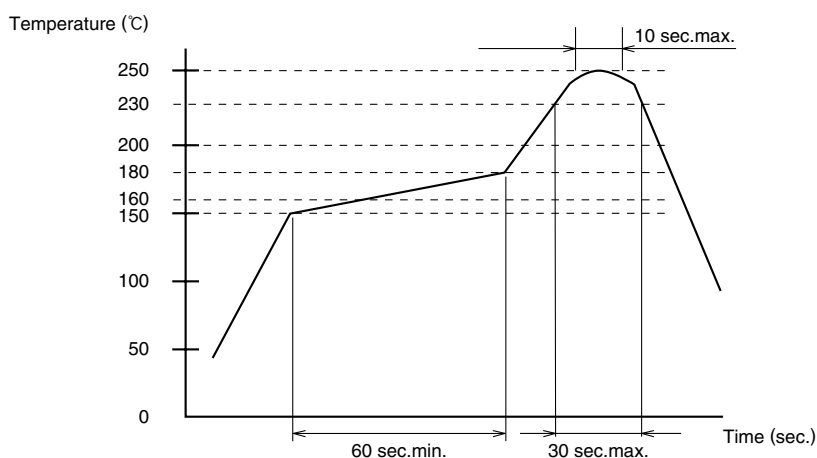

Using Lead-free Solder paste

① Maximum temperature	: 250°C
② Peak temperature time	: 10 sec. max.
③ Peak temperature	: 245°C to 250°C
④ 230°C min.	: 30 sec. max.
⑤ 150°C to 180°C	: 60 sec. min.

Metal mask thickness : 0.12 mm
 Reflow cycles : 2 cycles

◆ Precautions

1. Care should be taken to avoid accumulation of moisture inside the mounted receptacle after the washing process.
2. This product is intended to be used for circuit inspection only. Consult factory if any other application is considered.
3. The corresponding plug should be inserted in direction perpendicular to the switch mounting surface, within an angle of 2°. The push-in force should be kept within 6-10 N.
4. Do not use hand soldering for mounting on the board. Doing so could result in solder and flux wicking to the contact portion.
5. When using a heat gun, hotplate, or similar methods, limit the temperature to 260°C applied for 10 seconds max.
6. Consult Hirose if your application, installation methods or end-user environment are different than the recommended.



HRS

HIROSE ELECTRIC CO.,LTD.

5-23,OSAKI 5-CHOME,SHINAGAWA-KU,TOKYO 141-8587,JAPAN

PHONE: 81-3-3491-9741, FAX: 81-3-3493-2933

<http://www.hirose.com>