

2004.07.19 Preliminary

DESCRIPTION

The AP1098 is a linear, low current power amplifier in ISM band utilizing InGaP /GaAs HBT process. It features a LOW current of **85mA**, small signal gain of 25 dB, linear power of **19dBm** and PAE of **28%** for 802.11g under 3.3V. It can also be adjusted to smaller current (~60mA) with lower linear power (~16dBm). The AP1098 is housed in a 3 x 3 (mm), 16-pin, and QFN leadless package. The AP1098 is suitable to be used in portable, low current 802.11b and 802.11g WLAN applications.

Major Applications

- IEEE 802.11b/g WLAN system
- WLAN Portable Devices
- WLAN USB Devices
- Bluetooth and other 2.4 GHz ISM Band Application

Functional Block Diagram

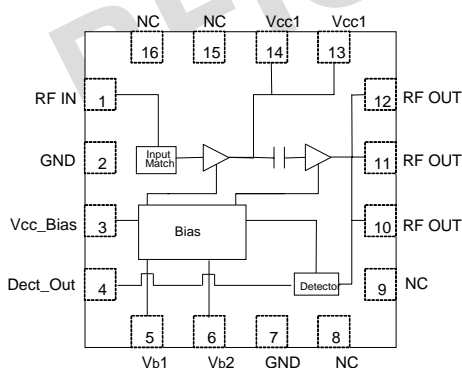

QFN- 16 pin, 3 x 3 (mm)

KEY FEATURES

- Ultra LOW Current (see below specs)
 - Ultra High Efficiency:
PAE>28% @802.11g linear power
 - Gain: 25 dB
- Under Vc=3.3V, Vref=3V
- * 11g
linear power: 19dBm
current: 85mA
 - * 11b
linear power: 23dBm
current: 165mA
- Low Idle Current: 25mA

Pin Details

| Pin Number | Name | Description |
|--------------|--------------|---|
| 1 | RF_IN | RF input. |
| 2 | GND | DC and RF ground. |
| 3 | Vcc_Bias | Supply voltage for bias circuit. |
| 4 | Dect_Out | Power detector output. |
| 5 | Vb1 | 1 st -stage control voltage |
| 6 | Vb2 | 2 nd -stage control voltage |
| 7 | GND | DC and RF ground. |
| 8 | NC | No contact (Connect to ground for better thermal dissipation.) |
| 9 | NC | No contact (Connect to ground for better thermal dissipation.) |
| 10 | RF_OUT | RF output. Require external matching. |
| 11 | RF_OUT | The detail configuration can be found in Application Notes |
| 12 | RF_OUT | The detail configuration can be found in Application Notes |
| 13 | VCC1 | Supply voltage for first stage. Some bypass capacitors are needed for system application. The detail configuration can be found in Application Notes. |
| 14 | VCC1 | Supply voltage for first stage. Some bypass capacitors are needed for system application. The detail configuration can be found in Application Notes. |
| 15 | NC | No contact (Connect to ground for better thermal dissipation.) |
| 16 | NC | No contact (Connect to ground for better thermal dissipation.) |
| Package Base | Center Metal | The package ground provides circuit ground as well as heat dissipation path for the power amplifier. |

© Vb2 can be connected with Vb1 pin into a single Vref through external resistor. (Please refer to the AP1098 Application note)

For more information, please contact us at:

Sales Dept.

Tel: +886-2-2698-1022

e-mail: sales@rfintc.com

© 2003 RF Integrated Corporation. All rights reserved.

RF integrated Corp. reserves the right to make any changes to the specifications without notice.

2004.07.19 Preliminary

Electrical Characteristics

Under $V_c=3.3V$, $V_{ref}=3V$, $T_a=25^\circ C$

| Parameter | Symbol | Test conditions | Min. | Typ. | Max. | Unit |
|---------------------------------------|------------------|--|------|-----------|------|------|
| Freq. | f | | 2.4 | | 2.5 | GHz |
| Total current | I _{cc} | @ P _{out} =19dBm, 64QAM/54Mbps @ P _{out} =23dBm, CCK/11Mbps | | 85 165 | | mA |
| Bias control reference current | I _{ref} | @ I _{cq} =25mA | | 0.7 | | mA |
| Power Gain | G _p | @ P _{out} =19dBm, 64QAM/54Mbps | | 25 | | dB |
| Quiescent current | I _{cq} | | | 25 | | mA |
| EVM at Output power 19dBm | EVM | @ P _{out} =19dBm, 64QAM/54Mbps | | 3 | | % |
| 802.11b ACP-1 st Side Lobe | | @ P _{out} =23dBm, CCK/11Mbps | | -36 | | dBc |
| 802.11b ACP-2 nd Side Lobe | | @ P _{out} =23dBm, CCK/11Mbps | | -56 | | dBc |
| Input VSWR | | | | 2 | | |
| Output VSWR | | | | 2.5 | | |
| PAE @ linear power | PAE | @ P _{out} =19dBm, 64QAM/54Mbps @ P _{out} =23dBm, CCK/11Mbps | | 28 37 | | % |

Absolute Maximum Ratings

| Parameter | Rating | Unit |
|---------------------------------|-------------|------|
| DC Power Supply For Collector | +5 | V |
| DC Supply Current For Collector | 280 | mA |
| RF Input Power | +5 | dBm |
| Operating Ambient Temperature | -40 to +85 | °C |
| Storage Temperature | -40 to +125 | °C |

Important Note:

The information provided in this datasheet is deemed to be accurate and reliable only at present time. RF Integrated Corp. reserves the right to make any changes to the specifications in this datasheet without prior notice.

For more information, please contact us at:

Sales Dept.

Tel: +886-2-2698-1022

e-mail: sales@rfintc.com

© 2003 RF Integrated Corporation. All rights reserved.

RF integrated Corp. reserves the right to make any changes to the specifications without notice.

2004.07.19 Preliminary

Data Charts

Fig. 1

EVM & Icc vs. Pout (dBm)@3.3V

(Vc1=Vc2=Vcc_bias=3.3V, Vref=3V, f=2.447GHz, 54Mbps OFDM Signal)

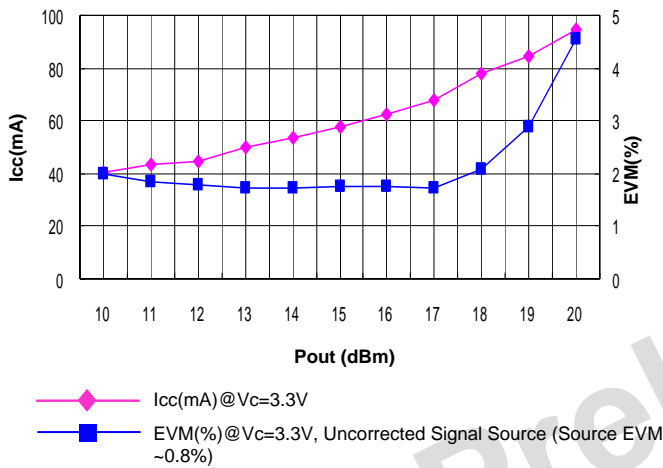

Fig. 2

Gain, EVM, PAE vs Pout

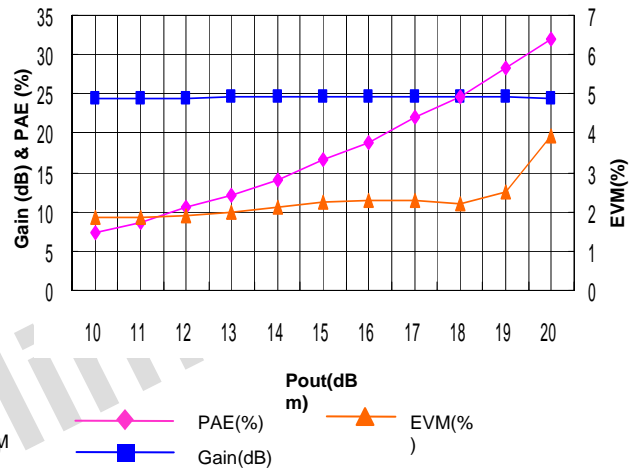

Fig. 3

Detector Output vs. Output Power

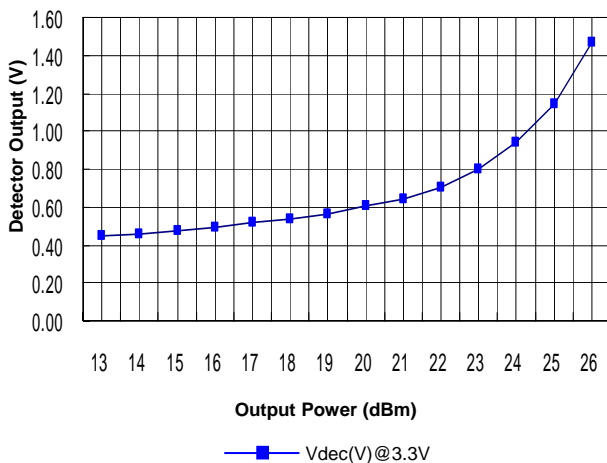
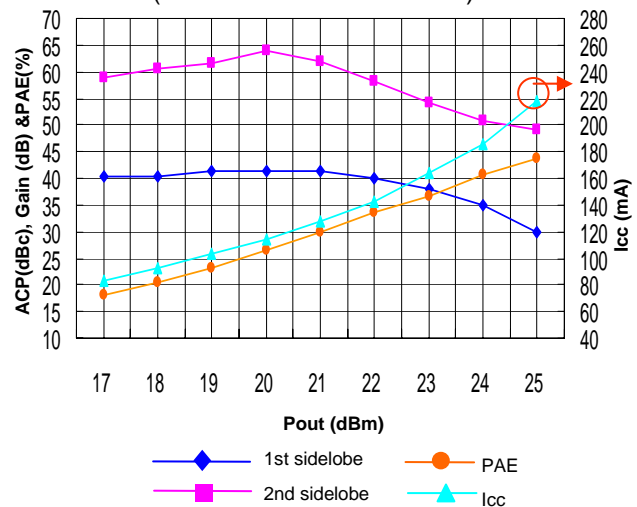

Fig. 4

Gain, ACP, PAE, Icc vs Pout_3.3V (With 11b CCK Modulation)



AP1098

For more information, please contact us at:
Sales Dept.
Tel: +886-2-2698-1022
e-mail: sales@rfintc.com

© 2003 RF Integrated Corporation. All rights reserved.

RF integrated Corp. reserves the right to make any changes to the specifications without notice.

2004.07.19 Preliminary

Data Charts

Fig.5

Power Gain vs. Frequency

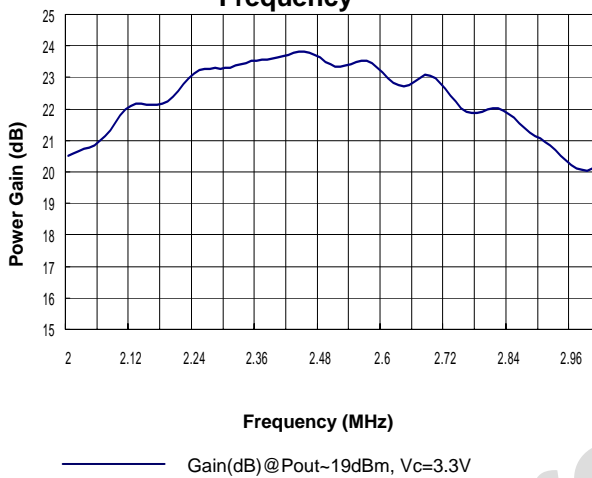

Fig. 6

Input Return Loss vs. Frequency

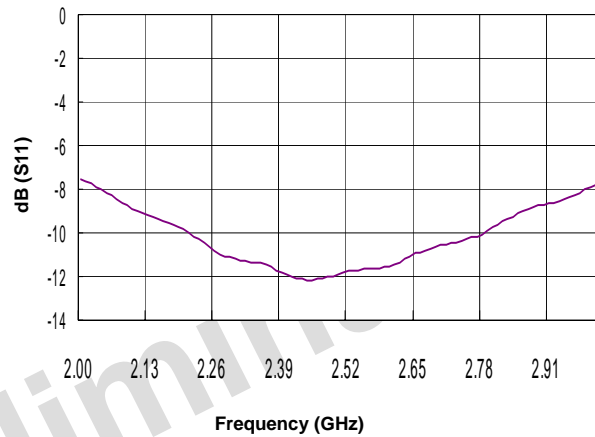

Fig. 7

Output Return Loss vs. Frequency

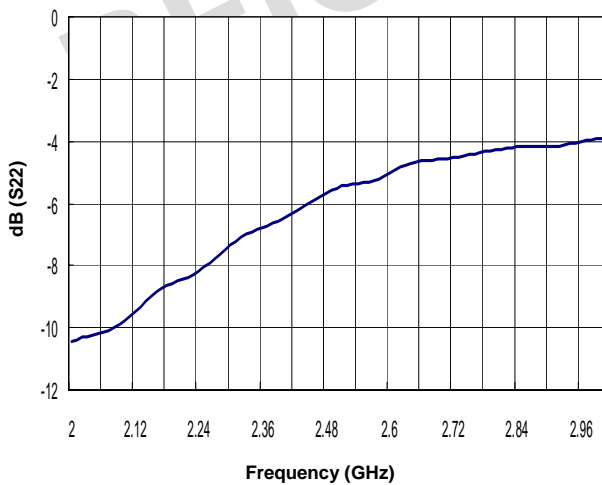
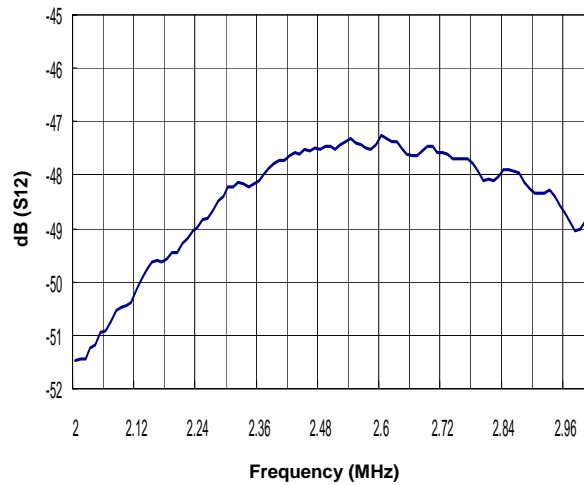

Fig. 8

Reverse Isolation vs. Frequency



AP1098

For more information, please contact us at:

Sales Dept.

Tel: +886-2-2698-1022

e-mail: sales@rfintc.com

© 2003 RF Integrated Corporation. All rights reserved.

RF integrated Corp. reserves the right to make any changes to the specifications without notice.

2004.07.19 Preliminary

Package Outline

Top View

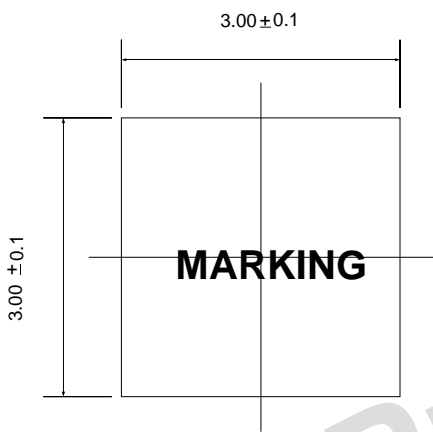

Bottom View

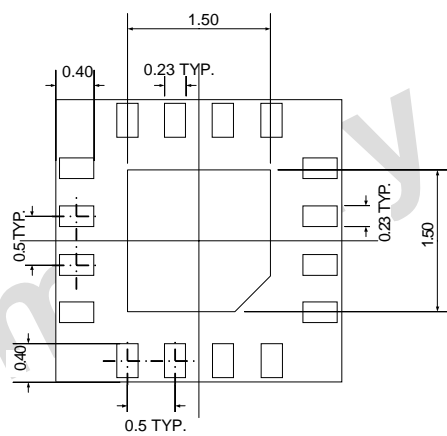

Unit: mm

Side View

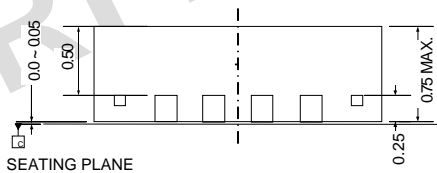

Note :

1. Dimension and tolerance conform to ASME Y14.5M-1994.
2. Refer to JEDEC STD. MO-220 WEED-2 ISSUE B

© For more detailed information, please refer to AP1098 Application Note.

For more information, please contact us at:

Sales Dept.

Tel: +886-2-2698-1022

e-mail: sales@rfintc.com

© 2003 RF Integrated Corporation. All rights reserved.

RF integrated Corp. reserves the right to make any changes to the specifications without notice.

This datasheet has been downloaded from:

www.DatasheetCatalog.com

Datasheets for electronic components.